

PANAG-IYA SA GOBYERNO  
DILI BALIGYA

# Kindergarten

Ikatulong Kwartar – Modyul 2: Semana 2

## Mga Kasinatian sa Pagkat-on

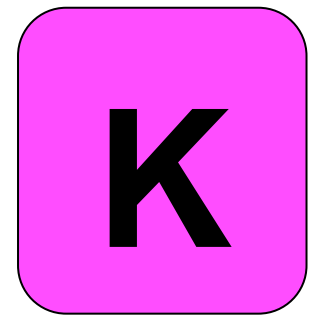

MILLIONOR R. BELARDE



SMILE

SUPPORT MATERIAL FOR INDEPENDENT LEARNING ENGAGEMENT (SMILE)

A Joint Project of the  
SCHOOLS DIVISION OF DIPOLOG CITY  
and the  
DIPOLOG CITY GOVERNMENT

**Kindergarten**  
**Support Material for Independent Learning Engagement (SMILE)**  
**Ikatulong Kwartar – Modyul : Mga Kasinatian sa Pagkat-on**  
**Unang Edisyon, 2020**

Gilatid sa Bata kang Balaod Akta Republika 8293, Seksyon 176 nga dinhi mahimong sundogon o kopyahon ang bisan unsang ginama sa Gobyerno sa Pilipinas. Hinoon, kon nay pagtugot sa hingtungdang ahensiya o opisina diin gigama ang maong materyales og kini adunay abot o kita. Apil sa mahimong buhaton sa nasangpit nga ahensiya ang pagkolekta ug kabayranan.

Ang mga tagsulat (estorya, seleksyon, balak, awit, hulagway, ngalan sa produkto o brand name, tatak, trademark, pasundayag sa telebisyon, pelikula ug uban pa) nga gigamit niini nga modyul, nagpakita og katungod sa pagpanag-iya.

Gipaningkamutan nga masubay ang mga tagsulat para makuha ang ilang pagtugot sa paggamit sa maong mga materyales nga gigamit niining modyul.

**Bumuo sa Pagsusulat ng Modyul**

<b>Manunulat:</b>	Millionor R. Belarde
<b>Editor:</b>	Helen B. Silao
<b>Magsusubli:</b>	Helen B. Silao
<b>Tigdibuho:</b>	
<b>Tighan-ay:</b>	Chithrill S. Maquiling
<b>Tigdumala:</b>	Virgilio P. Batan Jr. -Schools Division Superintendent Lourma I. Poculan -Asst. Schools Division Superintendent Amelinda D. Montero -Chief Education Supervisor, CID Nur N. Hussien -Chief Education Supervisor, SGOD Ronillo S. Yarag -Education Program Supervisor, LRMS Leo Martinno O. Alejo -Project Development Officer II, LRMS

**Gipatik sa Pilipinas sa**

**Department of Education – Region IX – Dipolog  
City Schools Division**

Adres sa Opisina:	Purok Farmers, Olingan, Dipolog City
Telefax:	(065) 212-6986
E-mail Address:	dipolog.city@deped.gov.ph

## QUARTER 3- WEEK 2: Lain-laing Lugar sa Komunidad

### **Pamantayang Pangnilalaman**

Ang bata adunay pagsabot sa konsepto sa pamilya, eskwelahan ug komunidad isip sakop niini.

### **Pamantayan sa Pagganap**

Ang bata makahimo sa pagpakita o pasigarbo ug kalipay nga makaistorya sa kaugalingong kaagi isip kauban sa pamilya, eskwelahan ug komunidad.

### **Most Essential Learning Competencies**

Makaila sa lain-laing lugar sa komunidad.

### **Content Focus:**

Lain-laing Lugar sa Komunidad

### **Unsa akong kinahanglang mahibaw-an?**

Aduna kitay mga lain-laing lugar nga makita sa komunidad. Atong ilhon kung unsa kining mga lain-laing lugar sa atong komunidad.

### **Unsa akong nahibaw-an?**

Isulti kini:

Hello, mga bata! Karong adlaw, anaa na pod kitay bag-ong panaghisgutan. Asa ka nagpuyo?

Unsay ngalan sa barangay nga imong gipuy-an?

Unsang mga lugar ang imo nang naadto nga sakop sa inyong komunidad?

Nakabalo ka ba nga naay lain-laing lugar sa atong komunidad?

Unsa ba ang mga lain-laing lugar sa atong komunidad? Masusi ba nimo kini?

# Unsay Bag-o?

## Buluhaton 1

Pagdumala: Kolori ang mga lugar nga makita sa atong komunidad.



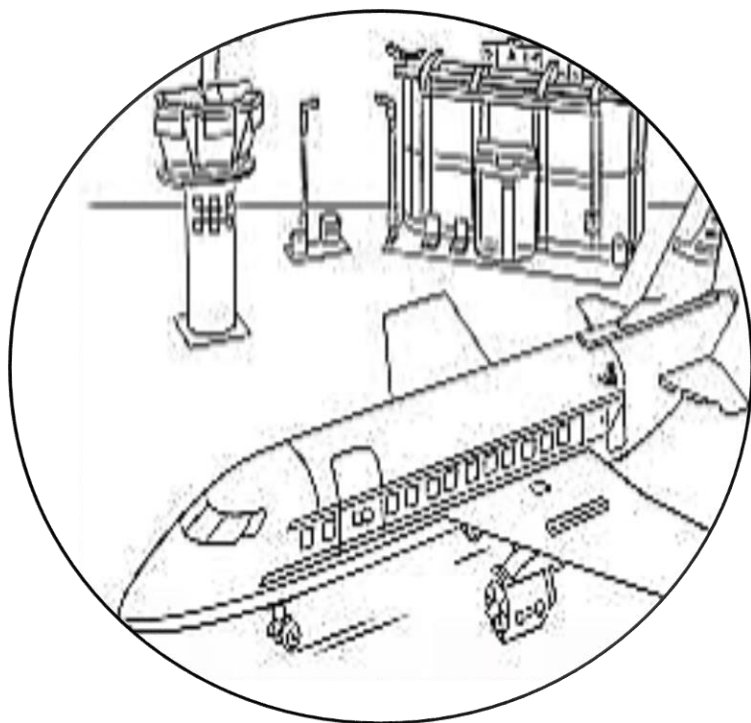

## Unsa Kana?

### Pagtuki kabahin sa buluhaton

#### Isulti kini:

Ipakita sa akoa ang imong nahimo.

Wow! Pagkanindot!

#### Pangutana:

Sa imong mga pinili nga mga lugar, nakaadto na ba ka aning mga lugara? Nag-unsa man ka didto?

#### Isulti kini:

Ang **komunidad** mao ang lugar diin kita nagpuyo. Diri makita ang lain-laing lugar sama sa simbahan, merkado, ospital, health center, eskwelahan, parke ug uban pa.

# Unsa pa Kaayo?

## Buluhaton 2

Pagdumala: Tabangi si Mario nga makauli sa ilang balay gikan sa eskwelahan. Isumpay-sumpay ang putol-putol nga mga linya.

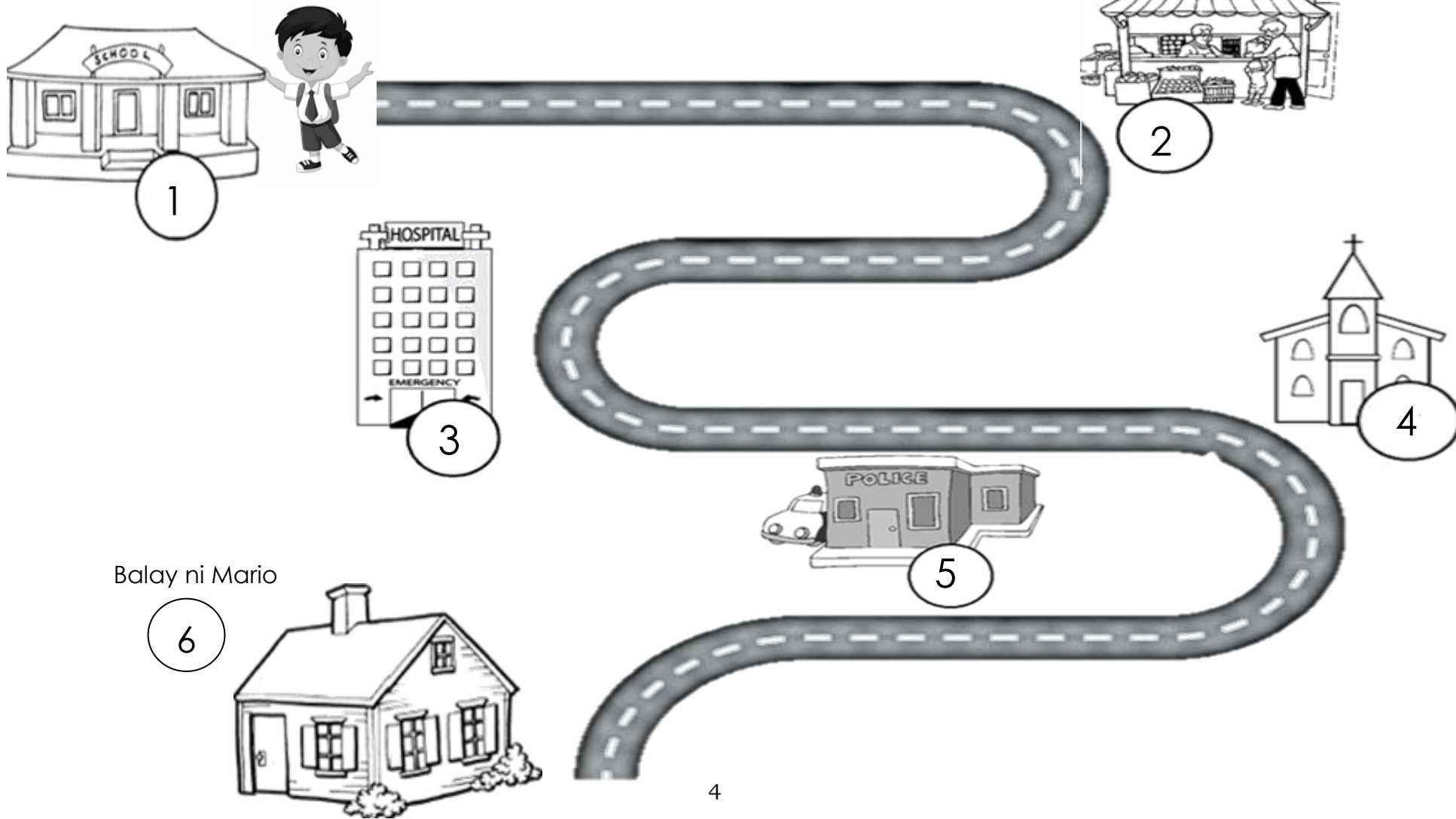

## Unsa akong Nahibaw-an?

### Pangutana:

Unsa kaayo ang mga nagkalain-laing lugar sa ilang komunidad ang naagian ni Mario ayha siya naabot sa ilang balay?

### Isulti kini:

Karon kahibalo na kamo nga ang atong komunidad adunay lain-laing lugar. Isulti ang mga lain-laing lugar nga makita sa inyong komunidad. Sumpayi kini...  
Ang mga lain-laing lugar sa akong komunidad mao ang \_\_\_\_\_.

## Unsa akong Mahimo?

### **Buluhaton 3**

Pagdumala: Tan-awa ang mga hulagway na diin mao kini ang mga lugar nga naagian ni Mario sa pagpauli niya sa ilang balay. Ihan-ay kini pinaagi sa pagbutang og numero 1, 2, 3, 4, 5, og 6 sugod sa una hangtod sa katapusang lugar.

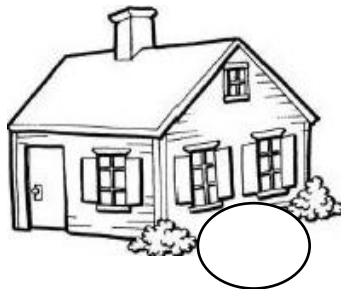

5

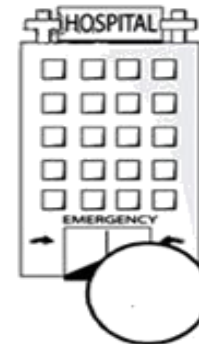

# Unsa Pa Kaayo?

## Buluhaton 4

Pagdumala: Asa kaha paingon ang mga tawo nga makita sa matag hulagway? Isumpay kini pinaagi sa linya.



•



•



•



•



•



•



•



•









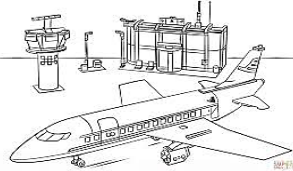

## Unsa Akong Nahibaw-an?

Nailhan mo na ba ang mga lain-laing lugar sa imong komunidad? Isulti ug unsa kining mga lugara?

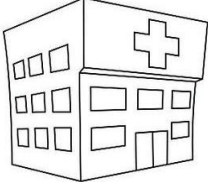
## Unsa Akong Mahimo?

### Buluhaton 5

Pagdumala: Pilia ang insaktong hulagway nga gipasabot sa mga ngalan nga naa sa walang bahin. Kolori kini.

<b>simbahan</b>	 
<b>parke</b>	 
<b>istasyon sa pulis</b>	 
<b>merkado</b>	 

## Unsa Pa Kaayo?

### Buluhaton 6

Pagdumala: Isumpay ang pareho nga anino nga mga lugar sa komunidad.

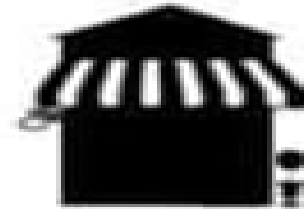
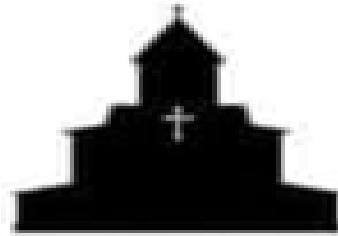

## Unsa Akong Nahibaw-an?

Pangutana:

Unsa man ang inyong nakat-on sa atong kalihokan karon?

Unsa man ang mga nagkalain-laing lugar sa imong komunidad? Importante ba ni sila?

Naghatag ba kinig kasulbaran sa panahon sa inyong panginahanglanon?

## Unsa Akong Mahimo?

**Buluhaton 7:**

Pagdumala: Tan-awa ang mga hulagway. Butangi og tsek ( / ) ang mga hulagway sa mga lugar nga makita sa imong komunidad ug ekis ( X ) ang mga lugar nga dili makita sa imong komunidad.

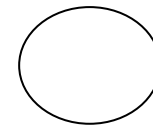
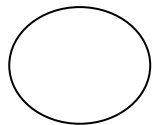
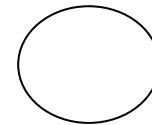
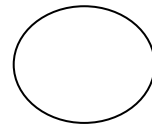
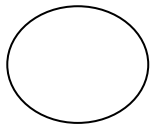

## Unsa Pa Kaayo?

### Buluhaton 8

Pagdumala: Ilha ang mga hulagway. Unsa kaayo kini? Isulat ang mga ngalan sa maong komunidad.  
Sundoga ang mga pulong nga anaa sa kahon.

<b>eskwelahan</b>	<b>ospital</b>
<b>merkado</b>	<b>parke</b>
<b>istasyon sa pulis</b>	<b>balay</b>



---

---

---

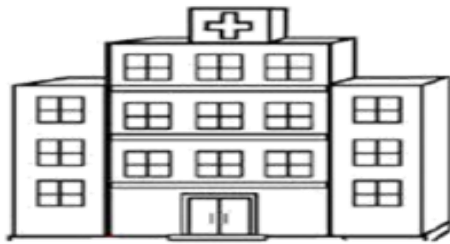

---

---

---



---

---

---



---

---

---



---

---

---

## Pakisayran

- [https://depedsilaycity.weebly.com/uploads/9/2/3/3/92338776/araling\\_panlipunan\\_2.pdf](https://depedsilaycity.weebly.com/uploads/9/2/3/3/92338776/araling_panlipunan_2.pdf)
- [https://www.google.com/search?q=klase+ng+komunidad&tbm=isch&source=iu&ictx=1&fir=u4g85weAzvxPEM%252CApuCh4705CPryM%252C\\_&vet=1&usg=AI4kSKdnsXvU9CGloySHvH3gSA5ODN9A&sa=X&ved=2ahUKewjdk\\_bBk7vuAhWbd94KHca1AUKQ9QF6BAgNEAE&biw=1280&bih=658&dpr=1.5#imgrc=nWFavOUIKjYJ4M](https://www.google.com/search?q=klase+ng+komunidad&tbm=isch&source=iu&ictx=1&fir=u4g85weAzvxPEM%252CApuCh4705CPryM%252C_&vet=1&usg=AI4kSKdnsXvU9CGloySHvH3gSA5ODN9A&sa=X&ved=2ahUKewjdk_bBk7vuAhWbd94KHca1AUKQ9QF6BAgNEAE&biw=1280&bih=658&dpr=1.5#imgrc=nWFavOUIKjYJ4M)
- <https://www.pinterest.ph/pin/403705554091400981/>
- <https://www.supercoloring.com/coloring-pages/birthday-cake-with-five-candles>
- <https://www.webtran.eu>
- K to 12 Most Essential Learning Competencies with corresponding codes- Kindergarten
- Kindergarten Teacher's Guide. (2017), First Edition. Vo. 1 & 2. Department of Education, Pasig City, Philippines
- Pagpahanas sa Pagpangandam, Sinugbuanong Binisaya, page 120, Ikapitong Limbag 2018. Department of Education, Pasig City, Philippines 1600